

 **West Marine**

Aurora Plus VHF Marine Radio

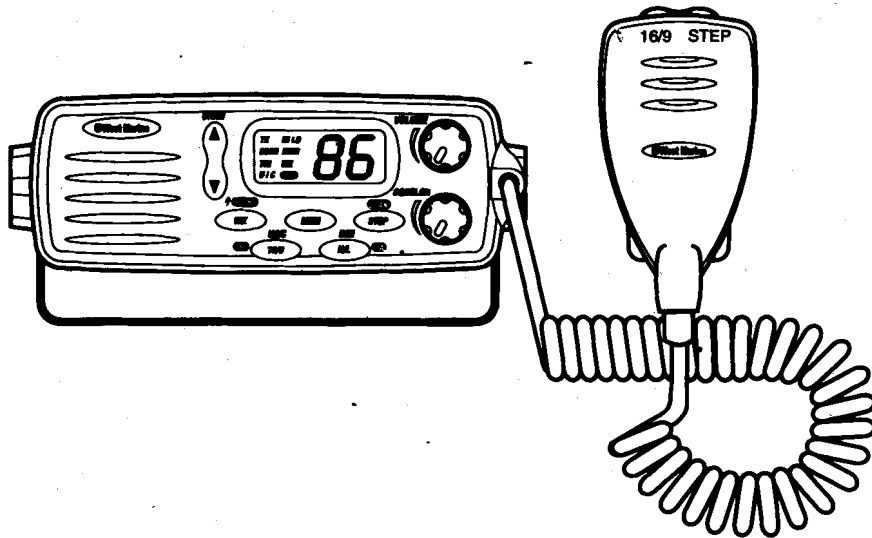

Operating Guide

Contents

West Marine Aurora Plus	1
Installation	2
Choosing a Location	2
Engine Noise Suppression	3
Antenna Considerations	3
Installing The Aurora Plus	3
Controls and Indicators	4
Front Panel	4
Rear Panel Connectors	5
Multi-Function Keys	7
Operation	9
Triple Watch	9
Manual Tuning	9
Instant Channel 16/Channel 9 Communications	9
Weather Scan	10
US/International/Canadian Channels	10
MEM (Entering channel numbers into Memory)	10
Memory Scan	11
Public Address	11
Weather Alert	11
Transmitting	12
Dimming the LCD Display Backlight and the TX Indicator	12
Optional Accessories	13
VHF FM Marine RadioTelephone Channel and Functions (USA Channels)	14
VHF FM Marine RadioTelephone Channel and Functions (International Channels)	15
VHF FM Marine RadioTelephone Channel and Functions (Canadian Channels)	16
Specifications	17

Maritime Radio Services Operation

Warning!

This transmitter will operate on channels/ frequencies that have restricted use in the United States. The channel assignments include frequencies assigned for exclusive use of the U.S. Coast Guard, use in Canada, and use in international waters. Operation in these frequencies without proper authorization is strictly forbidden. For frequencies/channels that are currently for use in the U.S. without an individual license, please contact the FCC Call Center at 1-888-CALL-FCC.

For individuals requiring a license, such as commercial users, you should obtain a license application from your nearest FCC field office.

West Marine Aurora Plus

The **West Marine Aurora Plus** VHF marine radio transceiver has been designed to give you a rugged, reliable instrument that will provide you with years of trouble-free service.

The technical excellence of the **West Marine Aurora Plus** is demonstrated by the many of uses for which it has been found acceptable by the U.S. Federal Communications Commission. The **West Marine Aurora Plus** is acceptable for compulsory use on "party boats," for use on vessels subject to the Great Lakes Radio Agreement or bridge-to-bridge requirements, for general pleasure and commercial vessels, and certain land stations in marine service.

The **West Marine Aurora Plus** is of all solid state design with conservatively rated rugged components and materials compatible with the marine environment. The transceiver utilizes a number of gaskets, sealing rings, waterproof membranes, and other sealants to effect a splashproof housing for protection of the electronics. The unit may be mounted in any number of convenient locations on your vessel by utilizing the universal mounting bracket.

You are encouraged to read the rest of this Operating Guide thoroughly to acquaint yourself with the characteristics and operation of your transceiver so that you can contribute to the longevity of your investment.

Be sure to complete the Product Registration Card at the back of this Guide, cut it out and mail it.

Keep your receipt as proof-of-purchase in case warranty service is required.

Features, Specifications, and availability of Optional Accessories are all subject to change without notice.

Installation

Caution: *The Aurora Plus will operate only with nominal 12 volt negative ground battery systems.*

It is important to determine carefully the most suitable location for your **Aurora Plus** on your vessel. Electrical, mechanical, and environmental considerations must all be taken into account. You must select the optimum relationship among these considerations.

Keep in mind the flexibility designed into the **Aurora Plus** so that you can most conveniently use your radio. Features which should be considered are:

1. The universal mounting bracket may be installed on either the top or bottom of a shelf, on a bulkhead, or for overhead mounting.
2. The REMOTE speaker jack can be used with an auxiliary speaker.
3. All connections are "plug-in" type for easy removal of the radio.
4. Front fire internal speaker allows convenient in-dash mounting using the optional bracket.

Choosing a Location

Some important factors to consider in selecting the location for your **Aurora Plus**:

1. Select a location that is free from spray and splash.
2. Keep the battery leads as short as possible. Direct connection to the battery is most desirable. If direct connection cannot be made with the supplied power lead, any extension should be made with #10 AWG wire. Long extensions should use larger gauge wire.
3. Keep the antenna lead as short as possible. Long antenna leads can cause substantial loss of performance for both receiving and transmitting.
4. Locate your antenna as high as possible and clear from metal objects. The reliable range of coverage is a direct function of antenna height.
5. Select a location that does not allow the radio to be subjected to direct sunlight (including that coming through windows).
6. Select a location that allows free air flow around the heat sink on the rear of the radio.
7. Select a location well away from the ship's compass. Auxiliary speakers also should be located away from the compass.

Engine Noise Suppression

Interference from the impulse noise generated by the electrical systems of engines is sometimes a problem with radios. The **Aurora Plus** has been designed to be essentially impervious to ignition impulse noise and alternator noise. However, in some installations it may be necessary to take measures to further reduce the effect of noise interference. All DC battery wires, antenna lead, and accessory cables should be routed away from the engine and engine compartment, and from power cabling carrying particularly high currents.

In severe cases of impulse noise interference, it may be necessary to install a noise suppression kit. Contact **West Marine** for more information.

Antenna Considerations

A variety of antennas is available from a number of quality suppliers. It is recommended you draw upon the advice of **West Marine** in determining a suitable antenna for your vessel and range requirements.

In general, communication range is increased by using a high-gain antenna placed as high as possible above the water line. Antennas should be located away from metal objects. Antennas should not have excessively long coaxial feed cables.

Installing The Aurora Plus

After you have carefully considered the various factors affecting your choice of location, position the radio (with the bracket, microphone, power cord, antenna and any auxiliary cables installed) into the selected location to assure there is no interference with the surrounding items. Mark the location of the mounting bracket. Remove the bracket from the radio and use it as a template to mark the holes to be drilled for the mounting hardware. Drill the holes and mount the bracket with hardware compatible with the material of the mounting surface.

Connect the red wire of the supplied power cord to the positive (+) battery supply. Connect the black wire of the power cord to ground. The power cord is equipped with a fuse to protect the radio. Use only a Six (6) Ampere fast blow fuse for replacement. Connect the power cord to the keyed connector on the power "pigtail" (See page 9).

Connect the antenna and all other auxiliary cables and accessories.

Install the radio in the mounting bracket and connect all cables and accessories to the appropriate jacks and connectors.

Controls and Indicators

Front Panel

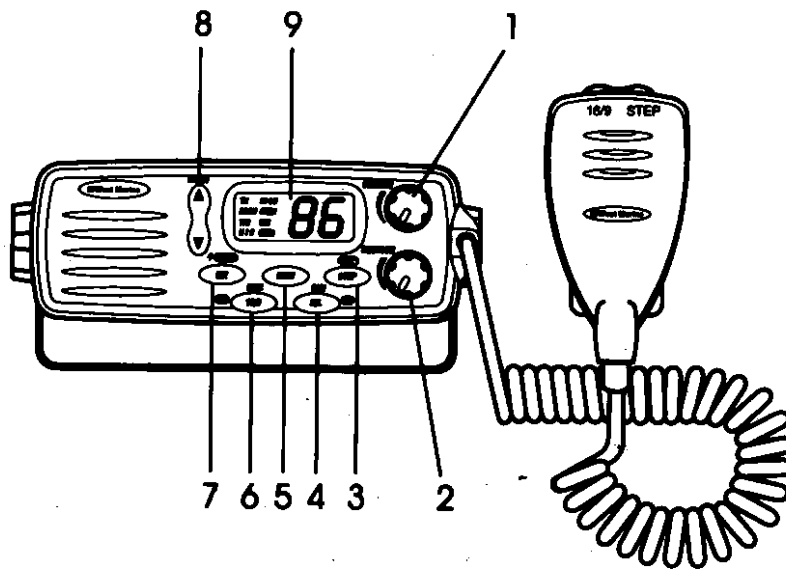

1. **VOLUME (On/Off/Volume)** - Turns the Aurora Plus On or Off and varies the audio output.
2. **SQUELCH** - Eliminates background noise when no signal is being received.

Note: Items 3 through 7 are Multi-Function keys. Refer to the "Multi-Function Keys" section for detailed descriptions.

3. **STEP**(also located on microphone)
4. **H/L (Hi/Low)**
5. **MEM**
6. **16/9 (Channel 16/Channel 9; also located on microphone)**
7. **WX (Weather)**
8. **CHAN** - This control is used to manually select the desired Communication Channel (01 - 28 and 60 - 88), or Weather Channel (0 - 9).
9. **LCD Panel** - Indicators for TX, SCAN, TRI, U I C, HI, LO, MEM, WX, WX ALERT, and Channel Number.

Rear Panel Connectors

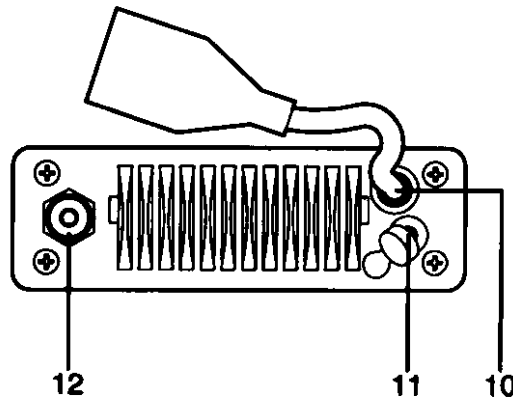

10. DC Power and PA Speaker Output - The "Pigtail" cord and connector are power in and PA Speaker out.
11. Remote Speaker Connector - An external 4 ohm, 4 Watt speaker may be connected to this jack. The connecting wire must have a miniature plug.
12. Antenna Connector - Connect the antenna here using a type PL259 connector.

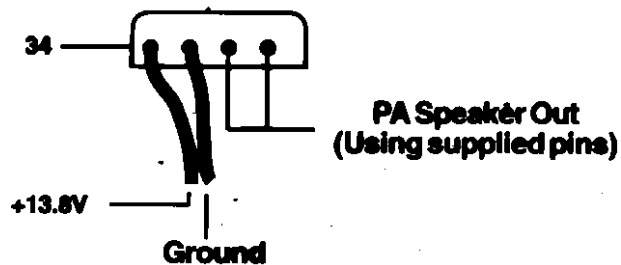

Supplied Power Cord - Connect supplied power cord to the keyed connector.

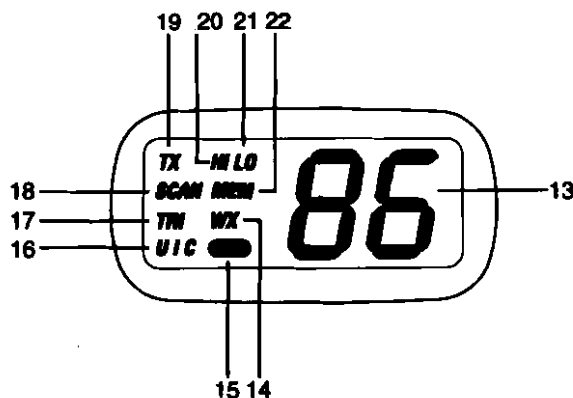

13. LCD Numerical Channel Display - Indicates Channel Number in use. Weather Channels are displayed as single digits. (Example: 0, 1, 2, 3, etc.) Communication Channels are displayed as two digits (Example: 01, 02, 03, etc.).

Note: LCD Status Indicators appear when status is selected by pressing the corresponding button.

14. WX - Indicates that Weather Channels have been selected. When pressed, remains active for eight (8) seconds.
15.  (Weather Alert) - Indicates that Weather Channels have been selected.
16. U (US) - Indicates that US Channels have been selected.
- I (International) - Indicates that International Channels have been selected.
- C (Canada) - Indicates that Canada Channels have been selected.
17. TRI (Triple Watch) - Indicates that Triple Watch has been selected.
18. SCAN - Indicates that you are scanning the channels in memory.
19. TX (Transmit) - LED lights when transmitting.
20. HI (High) - Indicates transmitted output is 25 Watts.
21. LO (Low) - Indicates transmitted output is 1 Watt.
22. MEM (Memory) - Indicates if the displayed channel is in memory for scanning.

Multi-Function Keys

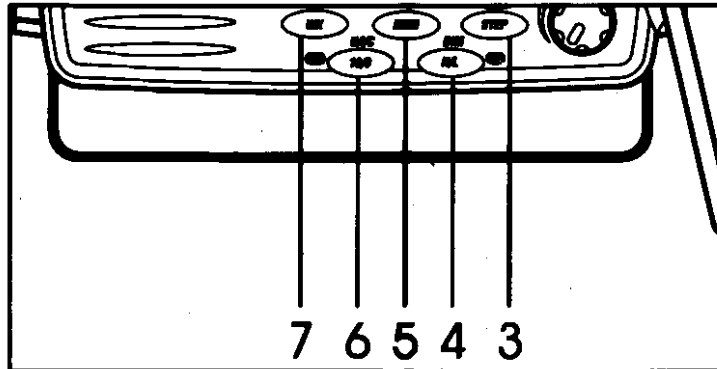

3. **STEP** - This key is used to step through the channels which are stored in memory. When pressed and held, this key also starts and stops the SCAN Mode.
 - Press STEP to step through the channels which are stored in memory.
 - Press and hold STEP to begin scanning the channels in memory. **Note:** Triple Watch is automatically activated when scanning begins.
4. **H/L** - This key allows you to select between high transmit power (25 watts), or low transmit power (1 Watt). Some channels may not allow highpower to be used.
 - Press H/L to switch between HI and LO output power.
 - Press and hold H/L to access the Public Address Mode.
 - Press and hold MEM, and then press H/L to adjust the brightness of the LCD Panel backlight and the brightness of the TX LED indicator.

The LCD Panel backlight and TX LED indicator are at their brightest level when the Aurora Plus is shipped from the factory.
5. **MEM** - This key enters the displayed channel into memory.
 - Press MEM to enter a selected channel in Memory Scan Mode.
 - Press and hold MEM, then press H/L to adjust the LCD Panel light intensity from a bright to a dim setting. Repeat this action to return to the bright intensity setting.
 - Press and hold MEM, and then press 16/9 to change the Channel Mode of Operation between US, International, or Canada.

6. **16/9** - This key allows rapid access to channels 16 and 9, the ability to select and deselect Triple Watch, and the ability to change between US, International, and Canadian channel banks.
 - Press 16/9 to access instant Channel 16/Channel 9 communications.
 - When the 16/9 key is pressed and held, it will initiate Triple Watch. When pressed and held a second time, it will turn off Triple Watch.
 - When the MEM key is pressed and held, followed by the 16/9 key, you can select between US, International, and Canadian channel banks.

7. **WX (Weather)** - This key is used to switch between monitoring weather channels and communication channels. This key is also used to activate Weather Alert.
 - Press WX to switch between weather and communication channels.
 - Press and hold WX to turn the Weather Alert Mode On/Off.

Operation

1. Turn the unit on by rotating the VOL control clockwise.
2. Adjust the SQUELCH control counterclockwise until you hear background noise, and then turn it clockwise until the noise just disappears.

Manual Tuning

To select a channel manually, press the CHAN selector buttons (up/down) to select the desired channel. Communication Channels are located on Channels 01 - 28 and 60 - 88.

Instant Channel 16/Channel 9 Communications

To access instant Channel 16 or Channel 9 communications, press 16/9. This overrides the channel selected with the CHAN selector buttons or any scanning activity. The Channel Display indicates the unit is on Channel 16. Press 16/9 again to access Channel 9 communications. Press 16/9 a third time to release the switch (Off). The transceiver will return to the channel selected prior to accessing instant Channel 16/Channel 9 communications. The Channel Display will indicate the selected channel.

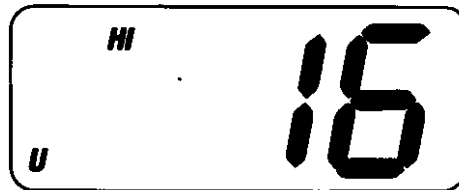

Triple Watch

Triple Watch monitors Channel 16 and Channel 9 for activity every two seconds while scanning or monitoring.

To activate Triple Watch, press and hold 16/9 until two short beeps occur. The *TRI* indicator appears on the LCD panel, indicating Triple Watch mode is in effect. If a signal is received on either Channel 16 or Channel 9, the radio remains on that channel until the signal ends.

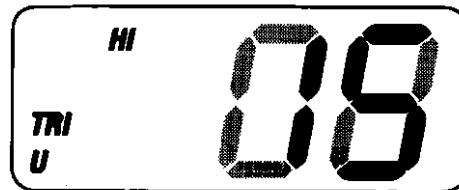

Press and hold 16/9 until the tone sounds to cancel Triple Watch Mode.

To cancel Channel 16/Channel 9 communications:

- Press 16/9 until previous channel setting appears.

—or—

- Press WX.

Weather Scan

To scan only Weather Channels 0 - 9, press WX. To select a Weather Channel manually, use the up/down keys. To scan for the strongest local station, press and hold the STEP key. The **WX** indicator will appear on the LCD Panel, indicating Weather Mode.

To exit from Weather Scanning:

- Press and hold STEP to end scan.
- Press 16/9 to change to Channel 16/Channel 9 communications

—or—

- Press WX to change to standard channel communications.

MEM (Entering channel numbers into Memory)

You can enter channels into Memory for instant scanning at any time. When a channel is selected for Memory, the **MEM** indicator will appear on the LCD display.

To enter a channel number into Memory, select the channel number you want stored by pressing the CHAN Selector button up or down, and then press MEM.

Scanning Channels in Memory

Once you have stored channels in the Aurora Plus' memory, you can use them in two ways: STEP and SCAN. By pressing the STEP button briefly, you can easily call up each of the channels in memory. If you press and hold the STEP button, the radio will rapidly check each channel in memory to see if there is traffic. If so, it will stop on that channel until the communications cease, and then continue scanning.

Public Address

To access the Public Address Mode, press and hold H/L. The **PR** icon will appear in the display. Press the Press-To-Talk switch on the microphone, hold the microphone approximately two inches from your mouth, and speak clearly in a normal voice. To cancel **PR**, press and hold H/L.

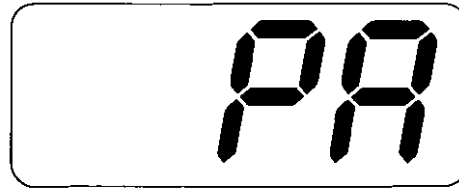

Weather Alert

The Weather Alert Mode can be activated to alert you of dangerous weather. When Weather Alert is turned on, and a warning signal is received, a siren will sound at full volume, regardless of the VOL setting. When the signal stops, you will hear the active weather channel broadcast at normal volume.

The  icon indicates the Weather Alert Mode is activated. To activate the Weather Alert Mode:

1. Press WX to select Weather mode press and hold WX.
2. Press and hold STEP to begin Weather Channel Scan.
—or—
1. Manually select the active Weather Channel after selecting WX.
2. Press and hold WX to activate the Weather Alert Mode. To cancel the Weather Alert Mode, press and hold WX again.

Transmitting

When the power is turned on, the transmitter is set for 25 Watts (except for USA Channels 13 and 67). The HI indicator will appear on the LCD Panel, indicating 25 Watt transmit power. USA Channels 13 and 67 transmit at 1 Watt regardless of the H/L selector setting. However, 25 Watt output for emergency use is available by pressing H/L while pressing the Press-To-Talk switch. When the H/L switch is released, the radio returns to the 1 Watt position.

One watt transmit power (LO) should be selected for most communications. This prevents your signal from interfering with other vessels' communications, and will work fine unless maximum range is required. Press the H/L button until LO is shown in the display.

Twenty-five watt transmit power (HI) provides greater range, and will allow your signal to be heard over weaker signals. It should be used only when necessary.

To activate the transmitter, press the Press-To-Talk switch on the microphone. The **TX** LED indicator will light, indicating a signal is being transmitted. Release the switch to receive. When transmitting, hold the microphone approximately two inches from your mouth and speak clearly in a normal voice.

Note: You cannot transmit on Weather Channels 0 - 9 or Channel 15. The Channel Number in the LCD Panel will blink to indicate these channels are "receive-only".

Dimming the LCD Display Backlight and the TX Indicator

When the Aurora Plus is turned on, the LCD Panel and **TX** LED will be brightest. Pressing the MEM and H/L buttons will change the brightness.

The last setting will remain in memory. When you turn on the radio the next time, the display will be at this setting.

Note that the **TX** LED is not turned Off by the DIM button.

Optional Accessories

- Flush mounting bracket for "in dash" installation.

Contact **West Marine** for information.

VHF FM Marine RadioTelephone Channel and Functions (USA Channels)

CHANNEL	FREQUENCY (MHz)		TYPE OF	SHIP	SHIP	PERMANENT
DESIG	TRANSMIT	RECEIVE	TRAFFIC	TO SHIP	TO SHORE	SCAN LIST
WX0	—	163.275	NOAA Weather	RX Only	RX Only	Weather
WX1	—	162.550	NOAA Weather	RX Only	RX Only	Weather
WX2	—	162.400	NOAA Weather	RX Only	RX Only	Weather
WX3	—	162.475	NOAA Weather	RX Only	RX Only	Weather
WX4	—	162.425	NOAA Weather	RX Only	RX Only	Weather
WX5	—	162.450	NOAA Weather	RX Only	RX Only	Weather
WX6	—	162.500	NOAA Weather	RX Only	RX Only	Weather
WX7	—	162.525	NOAA Weather	RX Only	RX Only	Weather
WX8	—	161.650	Can. Weather	RX Only	RX Only	Weather
WX9	—	161.775	Can. Weather	RX Only	RX Only	Weather
01	156.050	156.050	VTS	Yes	Yes	
02						
03	156.150	156.150	Port Ops	Yes	Yes	
05	156.250	156.250	VTS	Yes	Yes	
06	156.300	156.300	Safety	Yes	No	Coast Guard
07	156.350	156.350	Com'l	Yes	Yes	
08	156.400	156.400	Com'l	Yes	No	
09	156.450	156.450	Com'l & Non Com'l	Yes	Yes	Fish
10	156.500	156.500	Com'l	Yes	Yes	
11	156.550	156.550	Com'l	Yes	Yes	
12	156.600	156.600	Port Ops	Yes	Yes	
13	156.650	156.650	Navigational, TX 1W only	Yes	Yes	
14	156.700	156.700	Port Ops	Yes	Yes	
15	—	156.750	Environmental	RX Only	RX Only	Environmental
16	156.800	156.800	Safety Calling	Yes	Yes	
17	156.850	156.850	State Control	Yes	Yes	
18	156.900	156.900	Com'l	Yes	Yes	
19	156.950	156.950	Com'l	Yes	Yes	
20	157.000	161.600	Port Ops, RX Duplex	Yes	Yes	
21	157.050	157.050	Coast Guard	Yes	Yes	Coast Guard
22	157.100	157.100	Coast Guard	Yes	Yes	Coast Guard
23	157.150	157.150	Coast Guard	Yes	Yes	Coast Guard
24	157.200	161.800	Public Corresp. Duplex	No	Yes	Busy Tel.
25	157.250	161.850	Public Corresp. Duplex	No	Yes	Busy Tel.
26	157.300	161.900	Public Corresp. Duplex	No	Yes	Busy Tel.
27	157.350	161.950	Public Corresp. Duplex	No	Yes	Busy Tel.
28	157.400	162.000	Public Corresp. Duplex	No	Yes	Busy Tel.
60						
61	156.075	156.075				
63	156.175	156.175				
64	156.225	156.225				
65	156.275	156.275	Port Ops	Yes	Yes	
66	156.325	156.325	Port Ops	Yes	Yes	
67	156.375	156.375	Com'l, TX 1W only	Yes	No	
68	156.425	156.425	Non Com'l	Yes	Yes	Fish
69	156.475	156.475	Non Com'l	Yes	Yes	Fish
71	156.575	156.575	Non Com'l	Yes	Yes	Fish
72	156.625	156.625	Non Com'l	Yes	No	Fish
73	156.675	156.675	Port Ops	Yes	Yes	
74	156.725	156.725	Port Ops	Yes	Yes	
77	156.875	156.875	Port Ops	Yes	No	
78	156.925	156.925	Non Com'l	Yes	Yes	Fish
79	156.975	156.975	Com'l	Yes	Yes	
80	157.025	157.025	Com'l	Yes	Yes	
81	157.075	157.075	Coast Guard	Yes	Yes	Coast Guard
82	157.125	161.725	US Govt Only	Yes	Yes	
83	157.175	157.175	Coast Guard	Yes	Yes	Coast Guard
84	157.225	161.825	Public Corresp. Duplex	No	Yes	Busy Tel.
85	157.275	161.875	Public Corresp. Duplex	No	Yes	Busy Tel.
86	157.325	161.925	Public Corresp. Duplex	No	Yes	Busy Tel.
87	157.375	161.975	Public Corresp. Duplex	No	Yes	Busy Tel.
88	157.425	157.425	Com'l	Yes	No	

VHF FM Marine RadioTelephone Channel and Functions (International Channels)

CHANNEL DESIG	FREQUENCY (MHz)		TYPE OF TRAFFIC	SHIP		PERMANENT SCAN LIST
	TRANSMIT	RECEIVE		TO SHIP	TO SHORE	
WX0	—	163.275	NOAA Weather	RX Only	RX Only	Weather
WX1	—	162.550	NOAA Weather	RX Only	RX Only	Weather
WX2	—	162.400	NOAA Weather	RX Only	RX Only	Weather
WX3	—	162.475	NOAA Weather	RX Only	RX Only	Weather
WX4	—	162.425	NOAA Weather	RX Only	RX Only	Weather
WX5	—	162.450	NOAA Weather	RX Only	RX Only	Weather
WX6	—	162.500	NOAA Weather	RX Only	RX Only	Weather
WX7	—	162.525	NOAA Weather	RX Only	RX Only	Weather
WX8	—	161.650	Can. Weather	RX Only	RX Only	Weather
WX9	—	161.775	Can. Weather	RX Only	RX Only	Weather
01	156.050	160.650	VTS,Duplex	Yes	Yes	
02	156.100	160.700	Port Ops,Duplex	Yes	Yes	
03	156.150	160.750	Port Ops,Duplex	Yes	Yes	
04	156.200	160.800	Port Ops,Duplex	Yes	Yes	
05	156.250	160.850	VTS,Duplex	Yes	Yes	
06	156.300	156.300	Safety	Yes	No	
07	156.350	160.950	Com'l,Duplex	Yes	Yes	
08	156.400	156.400	Com'l	Yes	No	
09	156.450	156.450	Com'l & Non Com'l	Yes	Yes	Fish
10	156.500	156.500	Com'l	Yes	Yes	
11	156.550	156.550	Com'l	Yes	Yes	
12	156.600	156.600	Port Ops	Yes	Yes	
13	156.650	156.650	Navigational	Yes	Yes	
14	156.700	156.700	Port Ops	Yes	Yes	
15	156.750	156.750	Environmental	Yes	Yes	Environmental
16	156.800	156.800	Safety Calling	Yes	Yes	
17	156.850	156.850	State Control	Yes	Yes	
18	156.900	161.500	Com'l,Duplex	Yes	Yes	
19	156.950	161.550	Com'l,Duplex	Yes	Yes	
20	157.000	161.600	Port Ops,Duplex	Yes	Yes	
21	157.050	161.650	Coast Guard,Duplex	Yes	Yes	
22	157.100	161.700	Coast Guard,Duplex	Yes	Yes	
23	157.150	161.750	Coast Guard,Duplex	Yes	Yes	
24	157.200	161.800	Public Corresp,Duplex	No	Yes	Busy Tel
25	157.250	161.850	Public Corresp,Duplex	No	Yes	Busy Tel.
26	157.300	161.900	Public Corresp,Duplex	No	Yes	Busy Tel.
27	157.350	161.950	Public Corresp,Duplex	No	Yes	Busy Tel.
28	157.400	162.000	Public Corresp,Duplex	No	Yes	Busy Tel.
60	156.025	160.625	Duplex			
61	156.075	160.675	Duplex			
62	156.125	160.725	Duplex			
63	156.175	160.775	Duplex			
64	156.225	160.825	Duplex			
65	156.275	160.875	Port Ops,Duplex	Yes	Yes	
66	156.325	160.925	Port Ops,Duplex	Yes	Yes	
67	156.375	156.375	Com'l	Yes	No	
68	156.425	156.425	Non Com'l	Yes	Yes	Fish
69	156.475	156.475	Non Com'l	Yes	Yes	Fish
71	156.575	156.575	Non Com'l	Yes	Yes	Fish
72	156.625	156.625	Non Com'l	Yes	No	Fish
73	156.675	156.675	Port Ops	Yes	Yes	
74	156.725	156.725	Port Ops	Yes	Yes	
77	156.875	156.875	Port Ops	Yes	No	
78	156.925	161.525	Non Com'l,Duplex	Yes	Yes	
79	156.975	161.575	Com'l,Duplex	Yes	Yes	
80	157.025	161.625	Com'l,Duplex	Yes	Yes	
81	157.075	161.675	Coast Guard,Duplex	Yes	Yes	Coast Guard
82	157.125	161.725	US Govt Only,Duplex	Yes	Yes	
83	157.175	161.775	Coast Guard,Duplex	Yes	Yes	Coast Guard
84	157.225	161.825	Public Corresp,Duplex	No	Yes	Busy Tel.
85	157.275	161.875	Public Corresp,Duplex	No	Yes	Busy Tel.
86	157.325	161.925	Public Corresp,Duplex	No	Yes	Busy Tel.
87	157.375	161.975	Public Corresp,Duplex	No	Yes	Busy Tel.
88	157.425	162.025	Com'l,Duplex	Yes	No	Busy Tel

VHF FM Marine RadioTelephone Channel and Functions (Canadian Channels)

CHANNEL	FREQUENCY (MHz)		TYPE OF TRAFFIC	SHP TO SHIP	SHP TO SHORE	PERMANENT SCAN LIST
DESIG	TRANSMIT	RECEIVE				
WX0	—	163.275	NOAA Weather	RX Only	RX Only	Weather
WX1	—	162.550	NOAA Weather	RX Only	RX Only	Weather
WX2	—	162.400	NOAA Weather	RX Only	RX Only	Weather
WX3	—	162.475	NOAA Weather	RX Only	RX Only	Weather
WX4	—	162.425	NOAA Weather	RX Only	RX Only	Weather
WX5	—	162.450	NOAA Weather	RX Only	RX Only	Weather
WX6	—	162.500	NOAA Weather	RX Only	RX Only	Weather
WX7	—	162.525	NOAA Weather	RX Only	RX Only	Weather
WX8	—	161.650	Can. Weather	RX Only	RX Only	Weather
WX9	—	161.775	Can. Weather	RX Only	RX Only	Weather
01	156.050	160.650	Duplex	Yes	Yes	
02	156.100	160.700	Duplex	Yes	Yes	
03	156.150	160.750	Duplex	Yes	Yes	
04	156.200	156.200		Yes	Yes	
05	156.250	156.250		Yes	Yes	
06	156.300	156.300		Yes	No	
07	156.350	156.350		Yes	Yes	
08	156.400	156.400		Yes	No	
09	156.450	156.450		Yes	Yes	Fish
10	156.500	156.500		Yes	Yes	
11	156.550	156.550		Yes	Yes	
12	156.600	156.600		Yes	Yes	
13	156.650	156.650	1W	Yes	Yes	
14	156.700	156.700		Yes	Yes	
15	156.750	156.750	1W	Yes	Yes	Environmental
16	156.800	156.800		Yes	Yes	
17	156.850	156.850	1W	Yes	Yes	
18	156.900	161.500		Yes	Yes	
19	156.950	161.550		Yes	Yes	
20	157.000	161.900	Duplex, 1W	Yes	Yes	
21	157.050	157.050		Yes	Yes	
22	157.100	157.100		Yes	Yes	
23	157.150	161.750	Duplex	Yes	Yes	
24	157.200	161.900	Duplex	No	Yes	Buoy Tel.
25	157.250	161.950	Duplex	No	Yes	Buoy Tel.
26	157.300	161.900	Duplex	No	Yes	Buoy Tel.
27	157.350	161.950	Duplex	No	Yes	Buoy Tel.
28	157.400	162.000	Duplex	No	Yes	Buoy Tel.
60	156.025	160.625	Duplex			
61	156.075	156.075				
62	156.125	156.125				
63	156.175	156.175				
64	156.225	160.825	Duplex			
65	156.275	156.275		Yes	Yes	
66	156.325	156.325		Yes	Yes	
67	156.375	156.375		Yes	No	
68	156.425	156.425		Yes	Yes	Fish
69	156.475	156.475		Yes	Yes	Fish
71	156.575	156.575		Yes	Yes	Fish
72	156.625	156.625		Yes	No	Fish
73	156.675	156.675		Yes	Yes	
74	156.725	156.725		Yes	Yes	
77	156.875	156.875		Yes	No	
78	156.925	156.925		Yes	Yes	
79	156.975	156.975		Yes	Yes	
80	157.025	157.025		Yes	Yes	
81	157.075	157.075		Yes	Yes	Coast Guard
82	157.125	157.125		Yes	Yes	
83	157.175	157.175		Yes	Yes	Coast Guard
84	157.225	161.625	Duplex	No	Yes	Buoy Tel.
85	157.275	161.675	Duplex	No	Yes	Buoy Tel.
86	157.325	161.925	Duplex	No	Yes	Buoy Tel.
87	157.375	161.975	Duplex	No	Yes	Buoy Tel.
88	157.425	162.025	Duplex	Yes	No	Buoy Tel.

Specifications

General

Channels	: Transmit 54 Receive 77 Marine/10 Weather
Controls	: On-Off/Volume, Squelch
Status Indicators	: TX LED (transmit), SCAN, TRI, U, I, C, HI, LO, MEM, WX, and WX alert symbol on LCD Panel
Channel Display	: LCD (Dual 7 segment)
Selector Switch	: Channel Selector switch
Buttons	: WX, 16/9, MEM, H/L, and STEP
Connectors	: Antenna, remote speaker, and DC power
Size	: 2 1/5"H x 6 2/5"W x 8"L
Weight	: 2.4 lbs
Supply Voltage	: 13.8V DC negative ground
Standard Accessories	: Mounting bracket and hardware, DC power cord, microphone hanger, spare fuse
Antenna Impedance	: 50 Ω nominal
Microphone	: Rugged 1k Ω condenser mic element with coiled cord
Speaker	: 1.82 inch, 8 Ω -
Operating Temperature Range	: - 20°C to +50°C (- 4°F to +122°F)
Shock and Vibration	: Meets or exceeds EIA standards, RS152B and RS204C
FCC Approvals	: Type accepted under part 80 of the Rules; meets Great Lakes Agreement and party boat requirements

Transmitter

Power Output	: 1 watt or 25 watt (switch selectable)
Power Requirement	: Not rated on LO; 25 watts output: 4.5A @ 13.8V DC
Modulation	: FM ± 5 kHz deviation (FCC designator F3E)
Hum and Noise Signal-to-Noise	: 42 dB @ 300 HZ, 3kHz (nominal)
Audio Distortion	: Less than 3% with 3 kHz deviation with 1000 Hz modulating frequency (nominal)
Spurious Suppression	: - 56 dB @ 1 watt, - 65 dB @ 25 watts
Output Power Stabilization	: Built-in automatic level control (ALC)
Frequency Range	: 156 to 158 MHz
Frequency Stability:	: ± 1.58 kHz @ - 20°C to +50°C

Receiver

Frequency Range	: 156 to 163 MHz
Sensitivity	: 0.25 μ V for 12 dB SINAD 0.35 μ V for 20 dB S/N
Circuit	: Dual Conversion Super Heterodyne PLL
Squelch Sensitivity	: 0.5 μ v Threshold
Spurious Response	: 60 dB
Adjacent Channel Selectivity	: 60 dB @ ± 25 kHz
Audio Output Power	: 3.0 watts (10% Distortion)
Power Requirement	: 230 mA @ 13.8V DC squelched 0.7A @ 13.8V DC at maximum audio output
IF Frequencies	: 1st - 16.9 MHz 2nd - 455 kHz

Care and Maintenance

Your **Aurora Plus** is a precision piece of electronic equipment and you should treat it accordingly. Due to the rugged design, very little maintenance is required. However, a few precautions should be observed:

- If your radio has been accidentally subjected to spray or splash, you should immediately wipe it down with a soft cloth dampened with fresh water.
- If the antenna has been damaged, you should not transmit except in case of emergency. A defective antenna may cause damage to your radio.
- You are responsible for the continued FCC technical compliance of your radio.

Three Year Limited Warranty

WARRANTOR: West Marine

ELEMENTS OF WARRANTY: West Marine warrants, for three years, to the original retail owner, this West Marine Product to be free from defects in materials and craftsmanship with only the limitations or exclusions set out below.

WARRANTY DURATION: This warranty to the original user shall terminate and be of no further effect 36 months after the date of original retail sale. The warranty is invalid if the Product is (A) damaged or not maintained as reasonable or necessary, (B) modified, altered, or used as part of any conversion kits, subassemblies, or any configurations not sold by West Marine, (C) improperly installed, (D) serviced or repaired by someone other than an authorized service center for a defect or malfunction covered by this warranty, (E) used in any conjunction with equipment or parts or as part of any system not manufactured by West Marine, or (F) installed or programmed by anyone other than as detailed by the Operating Guide for this product.

STATEMENT OF REMEDY: In the event that the product does not conform to this warranty at any time while this warranty is in effect, warrantor will repair the defect and return it to you without charge for parts, service, or any other cost (except shipping and handling) incurred by warrantor or its representatives in connection with the performance of this warranty. THE LIMITED WARRANTY SET FORTH ABOVE IS THE SOLE AND ENTIRE WARRANTY PERTAINING TO THE PRODUCT AND IS IN LIEU OF AND EXCLUDES ALL OTHER WARRANTIES OF ANY NATURE WHATSOEVER, WHETHER EXPRESS, IMPLIED OR ARISING BY OPERATION OF LAW, INCLUDING, BUT NOT LIMITED TO ANY IMPLIED WARRANTIES OF MERCHANTABILITY OR FITNESS FOR A PARTICULAR PURPOSE. THIS WARRANTY DOES NOT COVER OR PROVIDE FOR THE REIMBURSEMENT OR PAYMENT OF INCIDENTAL OR CONSEQUENTIAL DAMAGES. Some states do not allow this exclusion or limitation of incidental or consequential damages so the above limitation or exclusion may not apply to you.

LEGAL REMEDIES: This warranty gives you specific legal rights, and you may also have other rights which vary from state to state. This warranty is void outside the United States of America.

PROCEDURE FOR OBTAINING PERFORMANCE OF WARRANTY: If, after following the instructions in this Operating Guide you are certain that the Product is defective, pack the Product carefully (preferably in its original packaging). Include evidence of original purchase and a note describing the defect that has caused you to return it. The Product should be shipped freight prepaid by traceable means, or delivered, to warrantor at:

West Marine
2395 Bert Dr.
Hollister, CA 95023
Phone - (408) 635-1301
FAX: - (408) 635-1313



 **West Marine**

© 1997, West Marine Products Inc., All Rights Reserved

Printed in the Philippines

